



# 1570nm Eye safe Laser Rangefinder Module 30km

Model: LRF25A02ES

## PRODUCT DESCRIPTION

The LRF25A02ES, a 1570nm eye-safe laser rangefinder utilizing diode-pumped OPO technology, is a high-tech product that seamlessly integrates optics, mechanics, and electronics. Its ranging capabilities are as follows:

Under standard visibility conditions, for targets with a size of  $\geq 0.05\text{m}^2$  (such as the DJI Phantom 4 drone), the operating range is  $\geq 5\text{km}$ .

Under standard visibility conditions, for large targets with a reflectivity of  $\geq 20\%$ , the operating range is  $\geq 30\text{km}$ .

For a target of  $2.3\text{m} \times 2.3\text{m}$  with a reflectivity of  $\geq 20\%$ , the operating range is  $\geq 15\text{km}$  under standard visibility conditions. This product features a small size, light weight, high reliability, and long lifespan, enabling high-precision distance measurement of distant targets. It finds wide application in various fields such as terrain mapping, geophysical exploration, mining, oil fields, ports, stations, airports, urban construction, road development, water conservancy projects, transmission

line surveys, hunting observation, golf, outdoor activities, search and rescue operations, moving target tracking, speed measurement, vehicle automatic control, automotive safety alarms, industrial control, and more.



## TECHNICAL SPECIFICATIONS

Eye safety/level	Class1/1M
Laser Wavelength	1570nm
Ranging Capability	Under standard visibility conditions, for targets with a size of $\geq 0.05\text{m}^2$ (such as DJI Phantom 4 drone), the operating range is $\geq 5\text{km}$ ; Under standard visibility conditions, for large targets with a reflectivity of $\geq 20\%$ , the operating range is $\geq 30\text{km}$ . $\geq 15\text{km}$ (under standard visibility, for a target of $2.3\text{m} \times 2.3\text{m}$ with a reflectivity of $\geq 20\%$ ).
Minimum Ranging Distance	50m
Ranging Accuracy	$\leq 1\text{m}$ (RMS)
Ranging Frequency	1~25Hz
Accuracy rate	$\geq 98\%$
Multi-target detection	$\geq 1$ . If more targets are needed, the communication protocol should be customized.
Trigger method	It has two triggering modes: internal triggering and external triggering. When externally triggered, the time synchronization error between the laser and the external trigger pulse is no more than 10us.
Divergence Angle	$\leq 1\text{mrad}$
Dimensions (Length * Width * Height)	$\leq 235.5\text{mm} \times 170\text{mm} \times 116\text{mm}$
Weight	$\leq 4300\text{g}$
Power Supply	28VDC $\pm 10\%$
Power Consumption	Average power consumption $\leq 50\text{W}$ , Peak power consumption $\leq 150\text{W}$
Communication Interface	RS422

Operating Temperature	-40°C~+60°C
Storage Temperature	-55°C~+70°C
Vibration and Shock	Meeting the relevant requirements of GJB150.16A.2009

## MECHANICAL DIMENSION( mm)

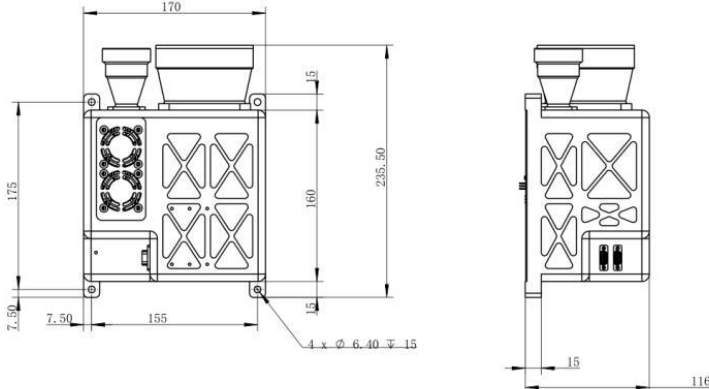

Mounting interface accepts customization

## ELECTRICAL INTERFACE

The upper computer and this rangefinder are connected through an aviation connector, which is an electrical interface.

1. Power supply interface: DC26V to DC30V (28VDC recommended); average power consumption  $\leq 30W$ , peak power  $\leq 250W$ ;
2. Communication interface: RS422.

Table 1 Electrical interface

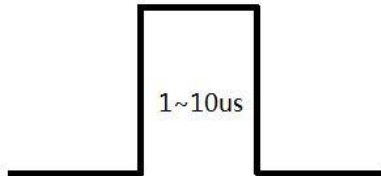
Electrical Interface Diagram	 J30J-15ZK (Aerospace Electric)	
Pin	interface definition	note
1~4	DC Power Supply	+28V DC
5~8	DC Power Supply Ground	+28V Ground
9	Serial Port T+ (Transmission + from Laser Rangefinder to Platform)	RS422
10	Serial Port R- (Reception - from Platform to Laser Rangefinder)	
11	Serial Port T- (Transmission - from Laser Rangefinder to Platform)	
12	Serial Port R+ (Reception + from Platform to Laser Rangefinder)	
13	RS422 Communication GND (Optional, can be left unconnected)	
14	 SYN+	RS422 Differential External Time Synchronization

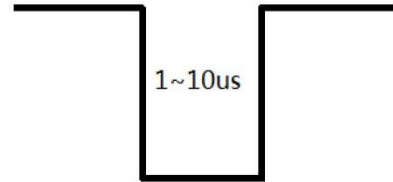
15		
upper computer electrical interface	SYN- J30J-15TJ with approx. 200 mm cable, supplied by the manufacturer	

## COMMUNICATION PROTOCOL

Communication Interface: Full-duplex RS422;

Communication Format: 1 start bit, 8 data bits, 1 stop bit, no parity bit;

Baud Rate: 115200bps;

Communication Mode: After power-on, the laser rangefinder defaults to the internal time synchronization mode, with the communication mode as follows:

**Internal Time Synchronization:** The laser rangefinder immediately sends serial data (see Table 3) to the host computer at the internal time synchronization frequency (20Hz or a set frequency). The host computer sends serial command data (see Table 2) to the laser rangefinder, and upon receipt, the rangefinder performs corresponding actions. There is no master-slave relationship in communication.

**External Time Synchronization:** The upper computer switches the rangefinder to external time synchronization mode through commands. The laser rangefinder immediately sends serial data (see Table 3) to the upper computer at the external time synchronization frequency (which must be  $\leq 20\text{Hz}$ ; the rangefinder stops working when the frequency is  $\geq 25\text{Hz}$ ). If the external time synchronization signal is not provided to the rangefinder, it does not return data. The commands for controlling the rangefinder from the upper computer are the same as in the internal time synchronization mode.

Table 2 Definition of communication frames for sending commands from the host computer to the range finder

Pin	Commands:	Code (HEX)	Commands:
1	Start distance measurement	55 0D 0D EE	Start laser distance measurement (begin emitting laser according to the synchronized frequency)
2	Stop distance measurement	55 0E 0E EE	Stop laser distance measurement
3	Set internal trigger frequency	55 14 XX YY EE	Set internal trigger frequency XX: Frequency value, ranging from 1 to 20Hz (values greater than 20 will be set to 20) YY: Checksum, calculated as $0x14 + \text{XX value}$ Note: The frequency can be changed when the device is in standby mode, but not during operation.
4	Internal trigger	55 0B 00 0B EE	Switch to internal trigger
5	External trigger	55 0B 01 0C EE	Switch to external trigger (the external trigger frequency must be $\leq 20\text{Hz}$ ; the rangefinder will stop working when the frequency is $> 25\text{Hz}$ .)

Table 3: Data Format for Laser Rangefinder Sending Data to Upper Computer

Pin	Function	Byte Content (HEX)	Description
1	Frame Header	0xEB	
2	Frame Header	0x90	
3	Rangefinder Status Information	1 byte	Bit0: 1 - Main Wave Present, 0 - No Main Wave Bit1: 1 - Echo Present, 0 - No Echo Bit2: 1 - Drive Current Abnormal, 0 - Drive Current Within Normal Range Bit3: 1 - APD High Voltage Abnormal, 0 - APD High Voltage Within Normal Range Bit4: 1 - TEC Temperature Not Reached, 0 - TEC Temperature Reached Bit5: 1 - External Trigger, 0 - Internal Trigger Bit6-Bit7: 10 - Timeout Warning, 01 - Operating, 00 - Standby

			(Default initial value for ranging status information: 0x00)
4	Laser Internal Trigger Frequency Value	1 byte	Laser Internal Trigger Frequency Value
5	High Byte of Distance	1 byte	High 8 bits of Integer Part of Distance Measurement Value (in meters)
6	Low Byte of Distance	1 byte	Low 8 bits of Integer Part of Distance Measurement Value (in meters)
7	Decimal Place Byte of Distance	1 byte	High 4 bits reserved, Low 4 bits for Decimal Part of Distance Measurement Value (in meters)
8	Checksum	1 byte	[3]-[7] Checksum

During the ranging process, the distance value can be in three states: a value of 0 indicates no laser output at that moment; a value of 65535 indicates that there is laser output but no received echo signal, which means the target distance is beyond the measurement range of the device (<100m) or there is no target; intermediate values indicate effective ranging.

The timeout warning state does not forcibly stop the laser. Users can issue commands to stop the laser based on actual situations.

## OPERATION STEPS AND PRECAUTIONS

### 1. Preparation before work



Figure 3 Host computer cable

- 1) Connect the upper computer cables to the upper computer equipment according to the electrical interface definitions in Table 1.
- 2) Ensure that the upper computer power supply is connected correctly, otherwise there is a risk of damaging the equipment.
- 3) Connect the connectors to the distance measuring device.

### 2. System power-up and operation

- 1) Power on the device, and the distance measuring device will start sending data to the upper computer according to the communication protocol. The default response content includes self-check information on the status of the distance measuring device.
- 2) Judge whether the device is normal based on the status word returned to the upper computer. The two necessary conditions for this distance measuring device to work properly are that both the APD high voltage and the operating temperature (TEC temperature) must be in a normal state before ranging can be performed. Especially for the operating temperature (TEC temperature), in various temperature environments, the distance measuring device needs to control the core temperature of the laser at a set temperature point before it can emit laser normally. Therefore, every time the distance measuring device is powered on, it requires some time for temperature control. This temperature control time is determined by the temperature difference between the ambient temperature and the set temperature. Especially in extremely low temperature environments, it may take up to 3 minutes for the temperature to stabilize.
- 3) When both the APD high voltage and the operating temperature (TEC temperature) status bits are 0 (normal), you can send a

start ranging command to perform laser ranging, and the distance and status bits will be updated according to the protocol.

- 4) Send a stop ranging command to stop laser ranging, and the status bits will be updated according to the protocol.
- 5) In the standby state of the distance measuring device, control commands can be used to set the internal or external time synchronization status of the device. Additionally, the internal trigger frequency (1-20Hz) can be set. After power cycling, it will revert to the default internal trigger frequency of 5Hz.

### 3. System Shutdown

- 1) Stop the operation of the distance measuring device through the upper computer.
- 2) Cut off the power supply to the laser.

### 4. Precautions for use

- 1) The laser emitted by this distance measuring device has a wavelength of 1572nm, which is safe for human eyes.
- 2) Ensure that the power supply polarity is connected correctly. Do not plug or unplug cables while the device is powered on to avoid permanent damage to the equipment.
- 3) When aligning the coaxial position of this distance measuring device with other photoelectric equipment, make sure to cover the receiving lens cap to prevent laser specular reflection from entering the receiving lens, which could lead to detector burnout.
- 4) This distance measuring device is not airtight. Avoid using it in high-humidity environments for long periods and ensure that the operating environment is clean and hygienic.
- 5) The optical lenses of this distance measuring device are coated with corresponding films. Please keep the optical lenses clean and use professional lens cleaning tools when wiping them.
- 6) The measurement range of the distance measuring device is related to atmospheric visibility and the nature of the target. In foggy, rainy, or windy and sandy conditions, the measurement range may be reduced. Targets such as white walls or exposed limestone have better reflectivity, which can increase the measurement range. Additionally, an increase in the inclination angle of the target to the laser beam will reduce the measurement range.
- 7) Do not dismantle this device without permission, otherwise, the warranty will be void.