



## 905nm Laser Rangefinder Module 1200m

Model:LRF1200A

### PRODUCT DESCRIPTION



This 905nm pulsed laser rangefinder module has a range of 1200m and is characterized by small size, light weight and long measuring distance. It can be applied to handheld rangefinder, micro UAV, rangefinder scope and so on. It has Uart (TTL\_3.3V) data transmission interface, and provides the upper computer software and communication protocol instruction set, which is convenient for users to carry out secondary development.

### TECHNICAL SPECIFICATIONS

Project	Technical data
Model	LRF1200A
Laser Wavelength	905nm
Eye Safety	Class1
Divergence Angle	1×6mrad
Receiving Field of View (FOV)	≤20mrad
Launch Lens Diameter	Φ10×7.5mm
Receiver Lens Diameter	Φ15×10mm
Measuring Range (3m x 3m Target)	≥5~1200m
Ranging Accuracy	±1m
Ranging Frequency	3Hz (5~45m) ; 0.75~3Hz (45~1200m)
Precision Rate	≥98%
False Alarm Rate	≤1%
Data Interface	UART (TTL_3.3V)
Supply Voltage	DC 3~5 V
Standby Power Consumption	≤1mW
Operating Power Consumption	≤1.5W
Weight	10±0.5g
Dimension (L×W×H)	25×26×13mm
Operation Temperature	-40~+60°C
Storage Temperature	-55~+65°C
Impact Resistance	1200 g, 1 ms
Anti-vibration	5~50~5 Hz, 1 Octave range /min, 2.5 g
Dependability	MTBF≥1500 h
Activation Time	≤200ms;
Protection Class	IP67
ESD Class	(Lens position)



	Contact discharge 6kV Air discharge 8kV
Electromagnetic Compatibility (EMC)	CE/FCC Certification
Eco-friendly	RoHS2.0

## MECHANICAL DIMENSION( mm)

The outside dimensions of the LRF1200A rangefinder module are as follows:

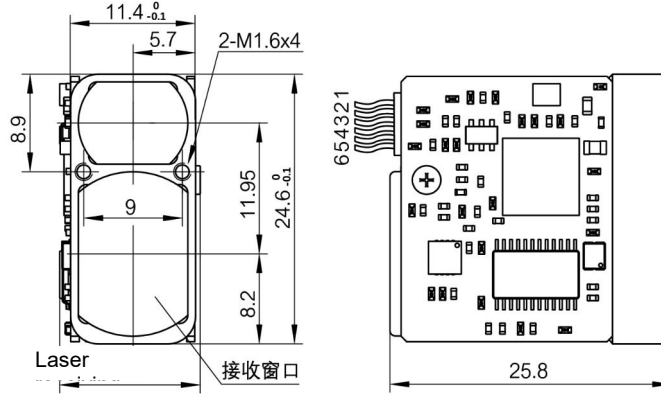

The center of mass of the LRF1200A ranging module is located as follows:

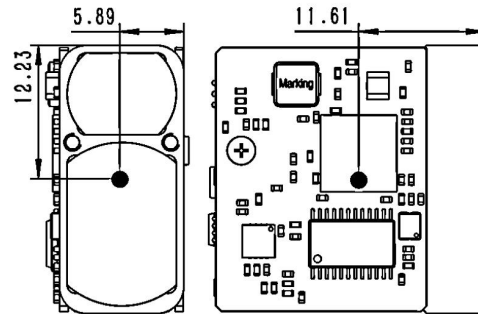

The recommended design of the mounting interface for the LRF1200A rangefinder module is as follows:

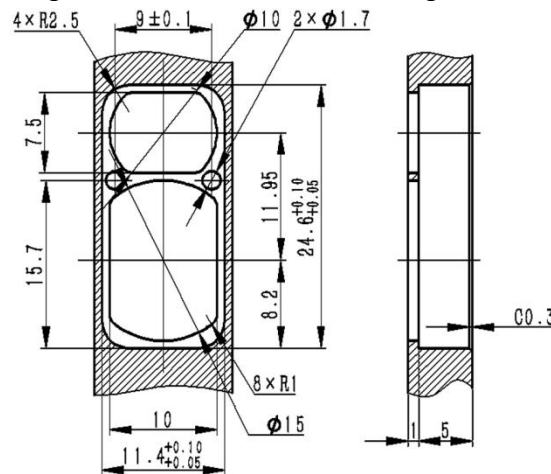

The window lens coating design requirements for the LRF1200A rangefinder module are as follows:

### Technical Requirement

1. ⊕ Permeation enhancement membrane,  $R < 0.5\% @ 905 \pm 15\text{nm}$ .
2. Protective chamfering.

## ELECTRICAL INTERFACE



User Electrical interface: UART (TTL\_3.3V)

The connector model of electrical interface is FWF08002-S06B13W5M (TXGA), and the specific wiring definition is shown in the table below.

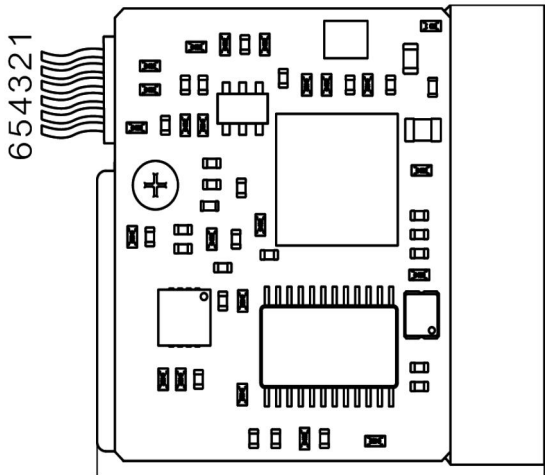

Pin	Definition	Description
1	GND	Serial ground
2	Power positive	
3	UART_NC	
4	UART_TX	Serial transmitter, TTL_3.3V level
5	UART_RX	Serial receiver, TTL_3.3V level
6	POWER_ON	Power switch, TTL_3.3V level (>0.7V ON, <0.15V OFF, Default OFF)

## COMMUNICATION PROTOCOL

### ● Communication rate and format

Format standard Baud rate (bps):	Format standard Baud rate (bps): 9600/14400/19200/38400/57600/115200 (default)/128000/230400.
Byte data format:	1 start bit, 8 data bits, 1 stop bit, no parity

### ● Basic format for sending data packets

Zone description	Number of bytes	Range of values	Remarks
Frame headers	2	0x55 0xAA	Fixed values
Command codes	1	0~255	Indicates the control object of the current control command
Data 1	1	0~255	
Data 2	1	0~255	
Data 3	1	0~255	
Data 4	1	0~255	
Checksum	1	0~255	Checksum is the command code, data 1 to 4 all bytes of data summed to the lower 8 bits

### ● Basic format of return packets

Zone description	Number of bytes	Range of values	Remarks
------------------	-----------------	-----------------	---------



Frame headers	2	0x55 0xAA	Fixed values
Command codes	1	0~255	Indicates the control object of the current control command
Data 1	1	0~255	
Data 2	1	0~255	
Data 3	1	0~255	
Data 4	1	0~255	
Checksum	1	0~255	Checksum is the command code, data 1 to 4 all bytes of data summed to the lower 8 bits

## ● Baud rate settings

The baud rates (bps) that can be set are: 9600, 14400, 19200, 38400, 57600bps, 115200, 128000, 230400, a total of eight baud rates can be set. The baud rate setting takes effect immediately after the baud rate is set and no re-powering is required.

Note: Transmit parity code = byte 3 + byte 4 + byte 5 + byte 6 + byte 7.

Receive checksum = byte 1 + byte 2 + byte 3 + byte 4 + byte 5 + byte 6 + byte 7.

Byte 3 (Command): 0x01 - set baud rate command.

Byte 7: specific baud rate setting parameters.

### Sent to the Ranging module:

Byte	1	2	3	4	5	6	7	8
Description	0x55	0xAA	0x01	0xFF	0xFF	0xFF	0x01	0xFF
Byte 7,Byte 8: 0x01,0xFF - baud rate 9600bps. 0x02,0x00 - baud rate 14,400bps. 0x03,0x01 - baud rate 19200 bps. 0x04,0x02 - baud rate 38400bps. 0x05,0x03 - baud rate 57600bps. 0x06,0x04 - baud rate 115200bps. 0x07,0x05 - baud rate 128000bps. 0x08,0x06 - baud rate 230400 bps.								

### The Ranging module returns:

Byte	1	2	3	4	5	6	7	8
Description	0x55	0xAA	0x01	status	0xFF	0xFF	0x01	Checksum
Status: 0x00 - baud rate setting failure. 0x01 - baud rate set successfully. Byte 7: 0x01 - baud rate 9600 bps. 0x02 - baud rate 14400 bps. 0x03 - baud rate 19,200 bps. 0x04 - baud rate 38400 bps. 0x05 - baud rate 57600 bps. 0x06 - baud rate 115200 bps. 0x07 - baud rate 128,000bps. 0x08 - baud rate 230,400 bps.								

## ● Single measurement

### Sent to the Ranging module:

Byte	1	2	3	4	5	6	7	8
Description	0x55	0xAA	0x88	0xFF	0xFF	0xFF	0xFF	Checksum

### The Ranging module returns:

Byte	1	2	3	4	5	6	7	8
Description	0x55	0xAA	0x88	Status	0xFF	DATA_H	DATA_L	Checksum
Status: 0 - single measurement failure (DATA_H=0xFF, DATA_L=0xFF). 1 - single measurement success (DATA_H=measurement result high Byte; DATA_L=measurement result low Byte).								



## ● Continuous measurement

### Sent to the Ranging module:

Byte	1	2	3	4	5	6	7	8
Description	0x55	0xAA	0x89	0xFF	0xFF	0xFF	0xFF	Checksum

### The Ranging module returns:

Byte	1	2	3	4	5	6	7	8
Description	0x55	0xAA	0x89	Status	0xFF	DATA_H	DATA_L	Checksum
Status: 0 - multiple measurement failure (DATA_H=0xFF, DATA_L=0xFF). 1 - multiple measurement success (DATA_H=measurement result high Byte; DATA_L=measurement result low Byte).								

## ● Stop continuous measurement

### Sent to the Ranging module:

Byte	1	2	3	4	5	6	7	8
Description	0x55	0xAA	0x8E	0xFF	0xFF	0xFF	0xFF	Checksum

### The Ranging module returns:

Byte	1	2	3	4	5	6	7	8
Description	0x55	0xAA	0x8E	Status	0xFF	0xFF	0xFF	Checksum
Status: 0 - stopping multiple measurements from failing. 1 - stopping multiple measurements successfully.								

Note: Data is returned in hexadecimal, all data results will be output by multiplying the real data by 10.

Example: dist = 1200.3m, output data is 12003, converted to 4E23 in hexadecimal, i.e. Data1 = 0x4E, Data2 = 0x23.