



Laser Rangefinder Module 0816C

Model:LRF0816C

OVERVIEW



LRF0816C eyesafe ranging module is developed based on 1535nm erbium-glass laser independently developed by our company. It belongs to level I eye-safe product. The product adopts monopulse ranging, the maximum range is up to 16km. Support UART(TTL_3.3V) and RS422 can choose, provide upper computer software, Specifies the set and communication protocol. The advantages are stable operation functions, small size and light weight.

TECHNICAL SPECIFICATIONS

Project	Technical data	
Model	LRF0816C	
Eye safety	Class1/1M	
Wavelength	1535±5nm	
Receiving aperture	Φ25 mm	
Firing aperture	Φ12 mm	
Receiving field of view Angle	4.21 mrad	
Beam divergence Angle	0.3±0.05 mrad	
Maximum range	Big goal	≥10000 m ¹⁾
	Car	≥ 8000 m ¹⁾
	People	≥ 4500 m ¹⁾
	Drone	≥2600 m ¹⁾
Minimum range	20 m	
Measurement frequency	1~10 Hz	
Ranging accuracy	±1 m	
Range resolution	≤30 m	
Detection probability	≥98%	
False alarm rate	≤1%	
Number of multiple target detections	3 (maximum number)	
Electrical interface	A1257WR-S-6P	
Supply	DC 4.5~16 V	
Standby power	≤ 1mW(Module off, POWER_ON < 0.3V)	
Average power consumption	≤ 2 W (Module on, POWER_ON > 2.7V)	
Start-up power consumption	≤14 W ²⁾	
Peak power consumption	≤10 W ²⁾	
Weight	≤ 58±1g	
Dimension (L×W×H)	65×48×32 mm	
Operation temperature	-40~+55°C	
Storage temperature	-55~+75°C	
Vibration	0.01~0.04 g ² /Hz, 20~2000Hz	
Strike	75g/6ms	



Multi-target detection	Up to 3 targets
Communication interface	UART(TTL_3.3V)、RS422 Can choose
Electrical isolation	Power, communication and structural isolation
Reliability	MTBF \geq 1500h
Optical axis stability	\leq 0.05 mrad
The optical axis is not perpendicular to the mounting base plane	\leq 0.5 mrad







Notes:

¹⁾ Car target size 2.3 m × 4.6 m; Humanoid target size 0.5 m × 1.7 m; UAV target size 0.2 m × 0.3 m ; Reflectivity 30%, Conspicuity \geq 12km;

²⁾The duration of start-up power consumption is less than 500ms; The duration of peak power consumption is less than 20ms and the average power consumption is less than 4W;

PRECAUTIONS FOR USE

● Safety mark

	【Danger】 Pay attention to laser radiation, the safety category of this product is Class 1, please take good safety protection.
	【Warn】 Improper use may cause personal injury.
	【Look out】 Improper use will cause damage to the ranging module.
	【Get an electric shock】 The working voltage of the ranging module is DC 4.5~16V, and the current is about 0.1~1A. Attention should be paid to protection when operating the ranging module.
	【Electrostatic protection】 The device is very sensitive to static electricity, which will cause irreversible damage to the device. The operator should take ESD protection during operation.
	【Environmental humidity】 When transporting, storing and using this product, pay attention to avoid humid environment. Working in humid environment prone to condensation and frost will affect the ranging performance and may cause damage to the module!

● Precautions for use

- (1) Do not disassemble the module and components. Improper operation will damage the ranging module and void the warranty.
- (2) When integrating the ranging module in the system, please read the product manual carefully. The wrong voltage will cause permanent damage.
- (3) When using, keep away from water and other liquids to avoid being polluted by dust or other pollutants.
- (4) During transportation and storage, store the modules in the delivered packaging.
- (5) Do not make any changes to the equipment, as this may cause potential hazards to operators and modules. It is forbidden to change any electronic, mechanical and optical components. Any modification to the equipment will void the warranty.
- (6) This ranging module does not need special maintenance, but it is necessary to keep the optical glass surface (transmitting and receiving lens) free of deposits. To ensure unobstructed measurement, use air blowing to remove dust. If dust or other deposits are difficult to remove, please contact the sales personnel.
- (7) In a very strong light environment, the performance of ranging may be reduced when the object with low surface reflectivity is ranging.



- (8) Ranging error may be increased by using glass, optical filter, plexiglass or other translucent materials.
- (9) Rain, snow, fog, haze, dust and other weather conditions will affect the ranging performance.
- (10) Avoid ranging under the condition of rapid temperature change, and the ranging performance will be affected.
- (11) **It is necessary to avoid ranging strong reflection targets (such as glass, smooth metal surface, etc.),** which may cause permanent damage to the detection components.
- (12) **It is necessary to avoid ranging the close range target within 15m,** which may cause permanent damage to the detection components.
- (13) **In order to avoid the possibility of permanent damage to the detection module when multiple ranging modules work in opposite direction in close range.**
- (14) **Avoid using high-energy laser source to direct the receiving antenna of the ranging module,** which may cause permanent damage to the detection module.
- (15) **When installing and using the ranging module, the mirror cover should always cover the receiving antenna.** Otherwise, it may cause permanent damage to the detection component.
- (16) Beyond the working conditions (including but not limited to working temperature, impact vibration magnitude, etc.), the use of the ranging module will cause damage to the ranging module and void the warranty.
- (17) If there is any damage, please do not operate and contact customer service for further assistance.

PRODUCT COMPOSITION

LRF0816C eye-safe ranging module is mainly composed of laser, transmitting antenna, receiving antenna, detection component, hardware circuit board, main structure, etc. The hardware circuit board is composed of main control board, power board and operational amplifier board.

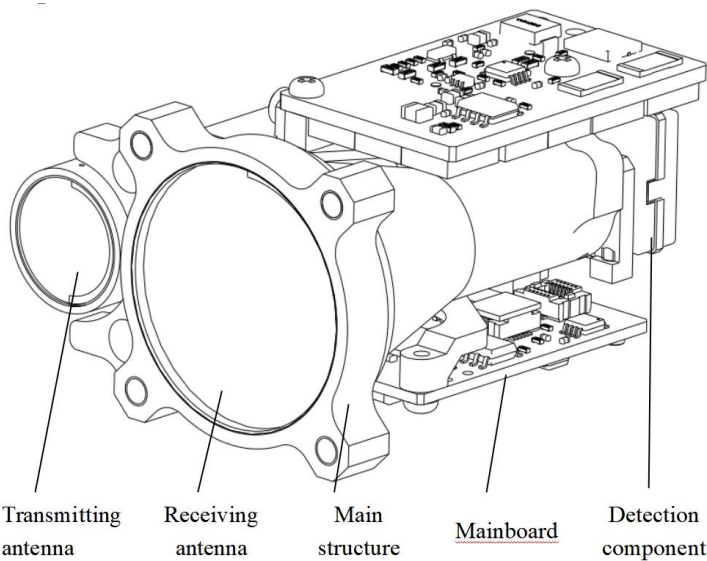

PUSER INTERFACE

● Electrical interface

1. User electrical interface: UART, TTL_3.3V

The connector model of electrical interface is A1257WR-S-6P, and the specific wiring definition is shown in the table below.

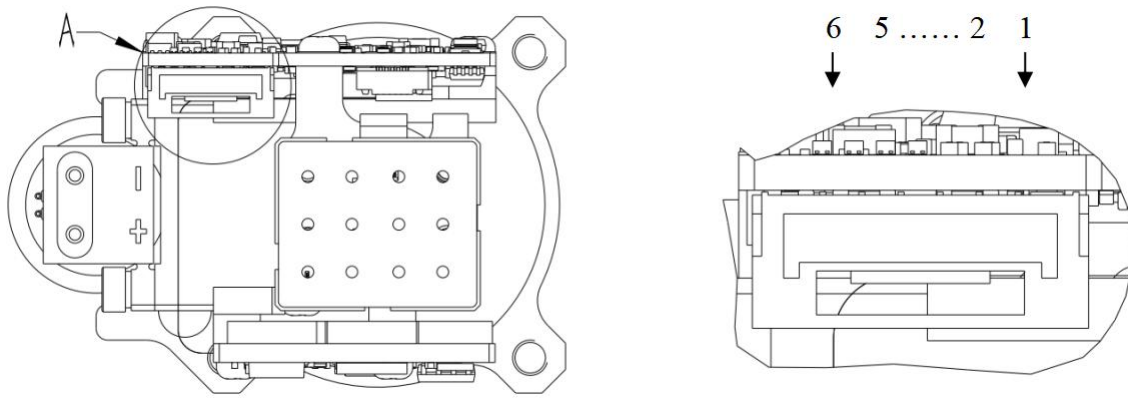

Pin	Definition	Description	Cable color
1	Power +	Power supply, DC 4.5~16V	Red
2	Power -	Power supply, GND	Black
3	POWER_ON	Module power switch, TTL_ 3.3V; Module on (> 2.7V), module off (< 0.3V);	White
4	UART_TX	UART_TX, TTL_3.3V	Yellow
5	UART_RX	UART_RX, TTL_3.3V	Green
6	UART_GND	UART_GND	Black

2. User electrical interface: RS422

Connector model: Yangtze River Connector A1257WR-S-6P, the specific definition is as shown in the following table:

Pin	Definition	Description	Cable color
1	Power +	Power supply, DC 4.5~16V	Red
2	Power -	Power supply, GND	Black
3	RS422_TX_P	Serial port transmitter+, RS422 level	White
4	RS422_TX_N	Serial port transmitter-, RS422 level	Yellow
5	RS422_RX_P	Serial port receiving terminal+, RS422 level	Green
6	RS422_RX_N	Serial port receiving end-, RS422 level	Black

● Dimensions

The overall dimension of the ranging module and the user installation interface are shown in the figure below.

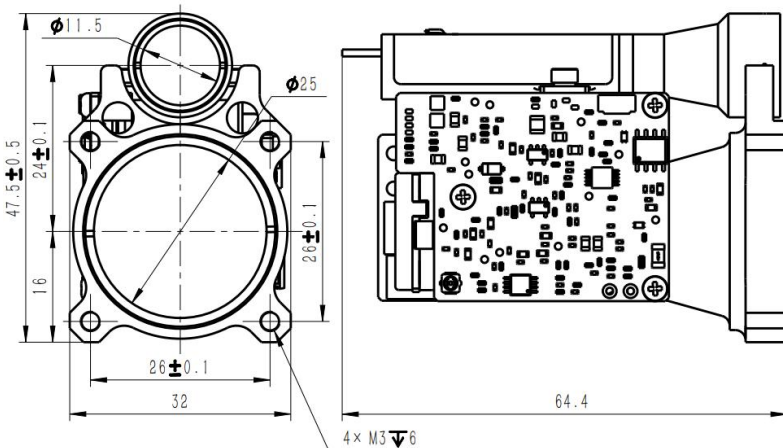



● Serial port Communication protocol

1. Communication speed and format

Format standard	Baud Rate:115200(default)/57600/9600 Data Format:n, 8, 1, MSB first.
-----------------	---

2. Data package format

Segment description	Segment length (Number of bytes)	Data range	Remarks
Frame head	2	0xEE 0x16	Fixed value
Data length	1	2~6	The data length is the total number of bytes in the three parts: Device code, Command code, and Command parameters
Device code	1	0x03	Fixed value, LRF-S series ranging module
Command code	1	0~255	Indicates the control object of the current control command
Command Parameters	0~4	0~255	Indicates the control object parameters of the current control command
Checksum	1	0~255	The checksum is the sum of all the bytes of data in the three parts of Device code, Command code, and Command parameters, which is 8 bits lower

3. Control commands (System → Ranging Module)

Command code	Description	Command Parameters length
0x01	Equipment Self-check	0
0x02	Single ranging	0
0x03	Set First/Last/Muilt Target	1
0x04	Continue ranging	0
0x05	Stop ranging	0
0xA0	Set baud rate	4
0xA1	Set continue ranging frequence	2
0xA2	Set minimum gating distance	2
0xA3	Query minimum gating distance	0
0xA4	Set maximum gating distance	2
0xA5	Query maximum gating distance	0
0xA6	Query FPGA software version	0
0xA7	Query MCU software version	0
0xA8	Query hardware version	0
0xA9	Query SN number	0
0x90	Query total light output times	0
0x91	Query light output times after power on	0



Response data (Ranging Module → System)

Command code	Description	Command Parameters length
0x01	Equipment Self-check	4
0x02	Single ranging	4
0x03	Set First/Last/Muilt Target	0
0x04	Continue ranging	4
0x05	Stop ranging	0
0x06	Ranging abnormal (only when the status in the ranging exception command is abnormal, the command is returned after the response command of single ranging or continuous ranging is returned)	4
0x07	Low power wake-up successful (after receiving the low-power wake-up command 0xa5, this command is returned)	0
0xA0	Set baud rate	4
0xA1	Set continue ranging frequence	2
0xA2	Set minimum gating distance	2
0xA3	Query minimum gating distance	2
0xA4	Set maximum gating distance	2
0xA5	Query maximum gating distance	2
0xA6	Query FPGA software version	4
0xA7	Query MCU software version	4
0xA8	Query hardware version	4
0xA9	Query SN number	3
0x90	Query total light output times	3
0x91	Query light output times after power on	3

4. Operation process

After the ranging module is powered on, it is in the power on mode by default (POWER_ON pulls the high level through the internal pull-up resistor). If the ranging module needs to be in the standby mode, the module power switch needs to be turned off (POWER_ON pulls the low level). After enabling the module power switch (POWER_ON is turned to high level), after about 0.5 s (the capacitor in the laser drive circuit is fully charged), all the command operations in 6.2 below can be performed.

● Communication Protocol

1. Equipment Self-check

(1) Send to ranging module:

Byte	0	1	2	3	4	5
Describe	0xEE	0x16	0x02 (data length)	0x03	0x01	Check_sum

(2) Get from ranging module:

Byte	0	1	2	3	4	5	6	7	8	9



Describe	0xEE	0x16	0x06(data length)	0x03	0x01	Status3	Status2	Status1	Status0	Check_sum
Status3 reserved										
Status2 echo intensity				0x00 ~ 0xff						
Status1 bit0 -- FPGA system status;				1 normal		0 abnormal				
bit1 -- laser light out state;				1 laser emission		0 laser don't emit light				
bit2 -- main wave detection state;				1 with main wave		0 without main wave				
bit3 -- echo detection status;				1 with echo		0 without echo				
bit4 -- bias switch status;				1 bias on		0 bias off				
bit5 -- bias output state;				1 bias normal		0 bias abnormal				
bit6 -- temperature status;				1 temp normal		0 temp abnormal				
bit7 -- laser PWM status;				1 laser PWM normal		0 laser PWM abnormal				
Status0 bit0 -- 5V6 power supply status;	1 normal					0 abnormal				
bit1 -- 15V power supply status;	1 normal					0 abnormal				

2. Single ranging

(1) Send to ranging module:

Byte	0	1	2	3	4	5
Describe	0xEE	0x16	0x02 (data length)	0x03	0x02	Check_sum

(2) Get from ranging module:

Byte	0	1	2	3	4	5	6	7	8	9
Describe	0xEE	0x16	0x06 (data length)	0x03	0x02	Status	Integer high 8 bits of distance	Integer low 8 bits of distance	Decimal of distance	Check_sum

First/Last Target ranging:

Status: 0x00 – indicates that the ranging result is single target;
 0x01 – including that another target before this target;
 0x02 – including that another target after this target;
 0x03 –reserved;
 0x04 – indicates that the ranging result is out of range(no target);
 0x05 –reserved;

Muilt Target ranging:

Status_bit3~0:

0x0 – indicates that the ranging result is single target;
 0x1 – including that another target before this target;
 0x2 – including that another target after this target;
 0x3 – including that another two targets before and after this target;
 0x4 – indicates that the ranging result is out of range(no target);
 0x5 –reserved;

Status_bit7~4:

0x0~0xf – indicates that the current distance result number; Value range [0, n-1], number of targets $1 \leq n \leq 16$;

3. Set First/Last/Muilt Target

(1) Send to ranging module:

Byte	0	1	2	3	4	5	6
Describe	0xEE	0x16	0x03 (data length)	0x03	0x03	Target	Check_sum
Target:	0x01 – Set First Target; 0x02 – Set Last Target;						



0x03 – Set Muilt Target;

(2) Get from ranging module:

Byte	0	1	2	3	4	5
Describe	0xEE	0x16	0x02 (data length)	0x03	0x03	Check_sum

4. Continue ranging

(1) Send to ranging module:

Byte	0	1	2	3	4	5
Describe	0xEE	0x16	0x02 (data length)	0x03	0x04	Check_sum

(2) Get from ranging module:

Byte	0	1	2	3	4	5	6	7	8	9
Describe	0xEE	0x16	0x06 (data length)	0x03	0x04	Status	Integer high 8 bits of distance	Integer low 8 bits of distance	Decimal of distance	Check_sum

First/Last Target ranging:

Status: 0x00 – indicates that the ranging result is single target;
 0x01 – including that another target before this target;
 0x02 – including that another target after this target;
 0x03 – reserved;
 0x04 – indicates that the ranging result is out of range(no target);
 0x05 – reserved;

Muilt Target ranging:

Status_bit3~0:

0x0 – indicates that the ranging result is single target;
 0x1 – including that another target before this target;
 0x2 – including that another target after this target;
 0x3 – including that another two targets before and after this target;
 0x4 – indicates that the ranging result is out of range(no target);
 0x5 – reserved;

Status_bit7~4:

0x0~0xf – indicates that the current distance result number; Value range [0, n-1], number of targets $1 \leq n \leq 16$;

5. Stop ranging

(1) Send to ranging module:

Byte	0	1	2	3	4	5
Describe	0xEE	0x16	0x02 (data length)	0x03	0x05	Check_sum

(2) Get from ranging module:

Byte	0	1	2	3	4	5
Describe	0xEE	0x16	0x02 (data length)	0x03	0x05	Check_sum

6. Ranging abnormal

(1) Get from ranging module:

Byte	0	1	2	3	4	5	6	7	8	9
Describe	0xEE	0x16	0x06	0x03	0x06	Reserve	Reserve	Reserve	Status	Check_sum



						d	d	d			
Status1 bit0 -- FPGA system status;						1 normal	0 abnormal				
bit1 -- laser light out state;						1 laser emission	0 laser don't emit light				
bit2 -- main wave detection state;						1 with main wave	0 without main wave				
bit3 -- echo detection status;						1 with echo	0 without echo				
bit4 -- bias switch status;						1 bias on	0 bias off				
bit5 -- bias output state;						1 bias normal	0 bias abnormal				
bit6 -- temperature status;						1 temp normal	0 temp abnormal				
bit7 -- laser PWM status;						1 laser PWM normal	0 aser PWM abnormal				
This instruction will be returned only when bit0 ~ 7 in status1 is abnormal.											

7. Set baud rate

(1) Send to ranging module:

Byte	0	1	2	3	4	5	6	7	8	9
Describe	0xEE	0x16	0x06	0x03	0xa0	BaudHigh24	BaudHigh16	BaudLow8	BaudLow0	Check_sum

(2) Get from ranging module:

Byte	0	1	2	3	4	5	6	7	8	9
Describe	0xEE	0x16	0x06	0x03	0xa0	BaudHigh24	BaudHigh16	BaudLow8	BaudLow0	Check_sum

8. Set continue ranging frequency

(1) Send to ranging module:

Byte	0	1	2	3	4	5	6	7
Describe	0xEE	0x16	0x04	0x03	0xa1	Freq	Num	Check_sum
Freq: 0x01~0x0A continue ranging frequency								
Num: 0x00 reserve								

(2) Get from ranging module:

Byte	0	1	2	3	4	5
Describe	0xEE	0x16	0x02	0x03	0xa1	Check_sum

9. Set minimum gating distance

(1) Send to ranging module:

Byte	0	1	2	3	4	5	6	7
Describe	0xEE	0x16	0x04	0x03	0xA2	DIS_H	DIS_L	Check_sum
DIS_H : High 8 bits of distance								
DIS_L : Lower 8 bits of distance								
DIS : 10~20000 Minimum gating distance, Unit m								

(2) Get from ranging module:

Byte	0	1	2	3	4	5	6	7
Describe	0xEE	0x16	0x04	0x03	0xA2	DIS_H	DIS_L	Check_sum
DIS_H : High 8 bits of distance								
DIS_L : Lower 8 bits of distance								
DIS : 10~20000 Minimum gating distance, Unit m								



10. Query minimum gating distance

(1) Send to ranging module:

Byte	0	1	2	3	4	5
Describe	0xEE	0x16	0x02	0x03	0xA3	0xA6

(2) Get from ranging module:

Byte	0	1	2	3	4	5	6	7
Describe	0xEE	0x16	0x04	0x03	0xA3	DIS_H	DIS_L	Check_sum
DIS_H :	High 8 bits of distance							
DIS_L :	Lower 8 bits of distance							
DIS :	10~20000 Minimum gating distance, Unit m							

11. Set maximum gating distance

(1) Send to ranging module:

Byte	0	1	2	3	4	5	6	7
Describe	0xEE	0x16	0x04	0x03	0xA4	DIS_H	DIS_L	Check_sum
DIS_H :	High 8 bits of distance							
DIS_L :	Lower 8 bits of distance							
DIS :	10~20000 Maximum gating distance, Unit m							

(2) Get from ranging module:

Byte	0	1	2	3	4	5	6	7
Describe	0xEE	0x16	0x04	0x03	0xA4	DIS_H	DIS_L	Check_sum
DIS_H :	High 8 bits of distance							
DIS_L :	Lower 8 bits of distance							
DIS :	10~20000 Maximum gating distance, Unit m							

12. Query maximum gating distance

(1) Send to ranging module:

Byte	0	1	2	3	4	5
Describe	0xEE	0x16	0x02	0x05	0xA5	0xA8

(2) Get from ranging module:

Byte	0	1	2	3	4	5	6	7
Describe	0xEE	0x16	0x04	0x03	0xA5	DIS_H	DIS_L	Check_sum
DIS_H :	High 8 bits of distance							
DIS_L :	Lower 8 bits of distance							
DIS :	10~20000 Maximum gating distance, Unit m							

13. Query FPGA software version

(1) Send to ranging module:

Byte	0	1	2	3	4	5
Describe	0xEE	0x16	0x02	0x03	0xA6	0xA9



(2) Get from ranging module:

Byte	0	1	2	3	4	5	6	7	8	9
Describe	0xEE	0x16	0x06	0x03	0xA6	Version	Date	MonYear	Author	Check_sum
Version :	bit7~bit4		Major version (1~15)							
	bit3~bit0		Minor version (0~15)							
eg:	0x10——V1.0									
Data :	Data (1~31)									
MonYear:	bit7~bit4		Month (1~12)							
	bit3~bit0		Year (0~15) , Corresponds to 2020-2035							
Author :	0x6c		cliu							
	0x5d		dwu							
	0xcc		cycheng							

14. Query MCU software version

(1) Send to ranging module:

Byte	0	1	2	3	4	5
Describe	0xEE	0x16	0x02	0x03	0xA7	0xAA

(2) Get from ranging module:

Byte	0	1	2	3	4	5	6	7	8	9
Describe	0xEE	0x16	0x06	0x03	0xA7	Version	Date	MonYear	Author	Check_sum
Version :	bit7~bit4		Major version (1~15)							
	bit3~bit0		Minor version (0~15)							
eg:	0x10——V1.0									
Data :	Data (1~31)									
MonYear:	bit7~bit4		Month (1~12)							
	bit3~bit0		Year (0~15) , Corresponds to 2020-2035							
Author :	0x00		jyang							
	0xf1		llfu							
	0x01		zqxiong							

15. Query hardware software version

(1) Send to ranging module:

Byte	0	1	2	3	4	5
Describe	0xEE	0x16	0x02	0x03	0xA8	0xAB

(2) Get from ranging module:

Byte	0	1	2	3	4	5	6	7	8	9
Describe	0xEE	0x16	0x06	0x03	0xA8	MBVS	CTVS	APDVS	LDVS	Check_sum
MBVS :	Motherboard hardware version number									
CTVS :	Control board hardware version number									
APDVS :	Probe board hardware version number									
LDVS :	Driver board hardware version number									
	bit7~bit4		Major version (1~15)							
	bit3~bit0		Minor version (0~15)							
eg:	0x10——V1.0									



16. Query SN number

(1) Send to ranging module:

Byte	0	1	2	3	4	5
Describe	0xEE	0x16	0x02	0x03	0xA9	0xAC

(2) Get from ranging module:

Byte	0	1	2	3	4	5	6	7	8
Describe	0xEE	0x16	0x05	0x03	0xA9	MonYear	Num_H	Num_L	Check sum
MonYear:	bit7~bit4 Month (1~12) bit3~bit0 Year (0~15), Corresponds to 2020-2035								
Num_H :	High 8 bits of SN number								
Num_L :	Lower 8 bits of SN number								
Num:	1~999 Number								

17. Query total light output times

(1) Send to ranging module:

Byte	0	1	2	3	4	5
Describe	0xEE	0x16	0x02	0x03	0x90	0x93

(2) Get from ranging module:

Byte	0	1	2	3	4	5	6	7	8
Describe	0xEE	0x16	0x05	0x03	0x90	PNUM3	PNUM2	PNUM1	Check sum
PNUM3:	Total light output times, bit23~bit16								
PNUM2:	Total light output times, bit15~bit8								
PNUM1:	Total light output times, bit7~bit0								

18. Query light output times after power on

(1) Send to ranging module:

Byte	0	1	2	3	4	5
Describe	0xEE	0x16	0x02	0x03	0x90	0x93

(2) Get from ranging module:

Byte	0	1	2	3	4	5	6	7	8
Describe	0xEE	0x16	0x05	0x03	0x90	PNUM3	PNUM2	PNUM1	Check sum
PNUM3:	Total light output times after power on, bit23~bit16								
PNUM2:	Total light output times after power on, bit15~bit8								
PNUM1:	Total light output times after power on, bit7~bit0								

EXAMPLES OF COMMON COMMUNICATION INSTRUCTIONS

● Equipment Self-check

SEND: ee 16 02 03 01 04
 RECV: ee 16 06 03 01 ff 00 f7 ff f9'

● Single ranging

SEND: ee 16 02 03 02 05
 RECV: ee 16 06 03 02 04 00 00 00 09

● Continue ranging



SEND: ee 16 02 03 04 07
RECV: ee 16 06 03 04 04 00 00 00 0b
RECV: ee 16 06 03 04 04 00 00 00 0b
RECV:

● Stop ranging

SEND: ee 16 02 03 05 08
RECV: ee 16 02 03 05 08

● Set First Target

SEND: ee 16 03 03 03 01 07
RECV: ee 16 02 03 03 06

● Set Last Target

SEND: ee 16 03 03 03 02 08
RECV: ee 16 02 03 03 06

● Set Muilt Target

SEND: ee 16 03 03 03 03 09
RECV: ee 16 02 03 03 06

● Set continue ranging frequence of 1Hz

SEND: ee 16 04 03 a1 01 00 a5
RECV: ee 16 02 03 a1 a4

● Set continue ranging frequence of 5Hz

SEND: ee 16 04 03 a1 05 00 a9
RECV: ee 16 02 03 a1 a4